

File number	Piece number



File Number TYS-PST3SK4-IDS

Stage mark FM

Page 15

# PST3S-K4 Star Tracker IDS

Signature

\_\_\_\_\_

\_\_\_\_\_

\_\_\_\_\_

\_\_\_\_\_

\_\_\_\_\_

\_\_\_\_\_

\_\_\_\_\_

\_\_\_\_\_

\_\_\_\_\_

\_\_\_\_\_

Edit : FUSHUXIN

Proofreading : LIU SHIXIONG

Check : WANG HONGQIANG

Standard check: CHAIYIN

Approval : WANGHAIJUN

## IDS 1: Performance Index

	File number	TYS-PST3SK4-IDS			
	Sub-system name				
	Device name	PST3SK4 Star Tracker		Stage mark	
	Device code				FM
Attitude Accuracy	Pointing: 5" (3 $\sigma$ ) Rolling: 50" (3 $\sigma$ )				
Dynamic Range	@ 0.1°/s: 5" (Pointing, 3 $\sigma$ ); 50" (Rolling, 3 $\sigma$ ); @ 0.5°/s: 8" (Pointing, 3 $\sigma$ ); 80" (Rolling, 3 $\sigma$ ); @ 1.0°/s: 10" (Pointing, 3 $\sigma$ ); 100" (Rolling, 3 $\sigma$ ); @ 2°/s: follow up				
Data Validity	>98%@ 0.5°/s; >96%@0.5°/s ~1.5°/s;				
Update Rate	$\geq 10$ Hz				
Acquisition Rate	Max. $\leq 2$ s				
Start-up Time	Better than 5s				
Exclusive Angle	Sun: better than 35°; Earth: better than 30°				
Timing Accuracy	0.5ms @ synchronization pulse (SYNC pulse)				
Quaternion Continuity	the scalar of quaternion: non-negative				
Communication Method	RS422				
Life Time	5years @500Km Orbit				
Reliability	$\geq 0.98$ @ the end of 5years running				
Edited (Date) :					
Signed (Date) :		Mark	Changed number	Signature, date	

## IDS 2: Mechanical Characteristics

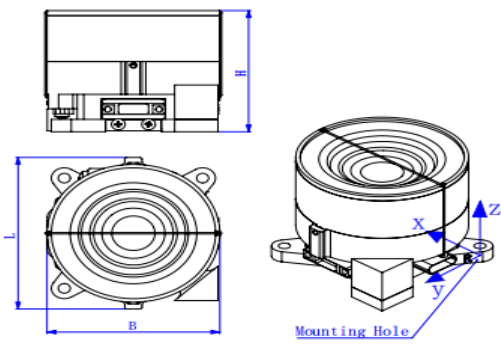
		File number		TYS-PST3SK4-IDS								
		Sub-system name										
		Device name		PST3SK4 Star Tracker		Stage mark						
		Device code				FM						
Device weight <sup>note)</sup>		60 ± 10g		Device number: 1		√						
Weight charact eristics	Envelope size mm		Envelope diameter: 44±1×40±1		Height(fold): 35±1		Height(Deployed): 75±2		√			
	Centroid position mm		X: 16±1		Y: 16±1		Z: 17±1		√			
	Inertia of centroid kg.mm <sup>2</sup>		P <sub>X</sub> =12±2		P <sub>Y</sub> =11±2		P <sub>Z</sub> =12±2		√	Mea- sure- ment	Calc- ulatio- n	Esti- mate
Install ation charact eristics	Installed holes number: 3		Size of installed holes (tolerance) mm: Φ2.8±0.1			Material:2A12-T4		Determination method (√)				
	Installation contacting area mm <sup>2</sup> : 380			Note:								
	Installation surface flatness : 0.1mm/100mm <sup>2</sup>											
	Installation surface roughness Ra μm: 3.2											
Installation surface state: the installation area is oxidized by conduction, and the remaining area is oxidized black.												
<p>Parameter relationship diagram (the relative relationship between the coordinate frames, position of centroid, size of device body, location of installation surface, etc.):</p> <p>Note: the determination method refers to the way to determine the weight of device.</p>												
												
<p>Note: The origin of the coordinates is located at the geometric center of the outer surface of the lower shell (see "Instrument diagram");</p>												
Edited (Date) :												
Signed (Date) :				Mark		Changed number		Signature, date				

### IDS 3: Instrument Diagram

	File number	TYS-PST3SK4-IDS		
	Sub-system name			
	Device name	PST3SK4 Star Tracker	Stage mark	
	Device code			FM

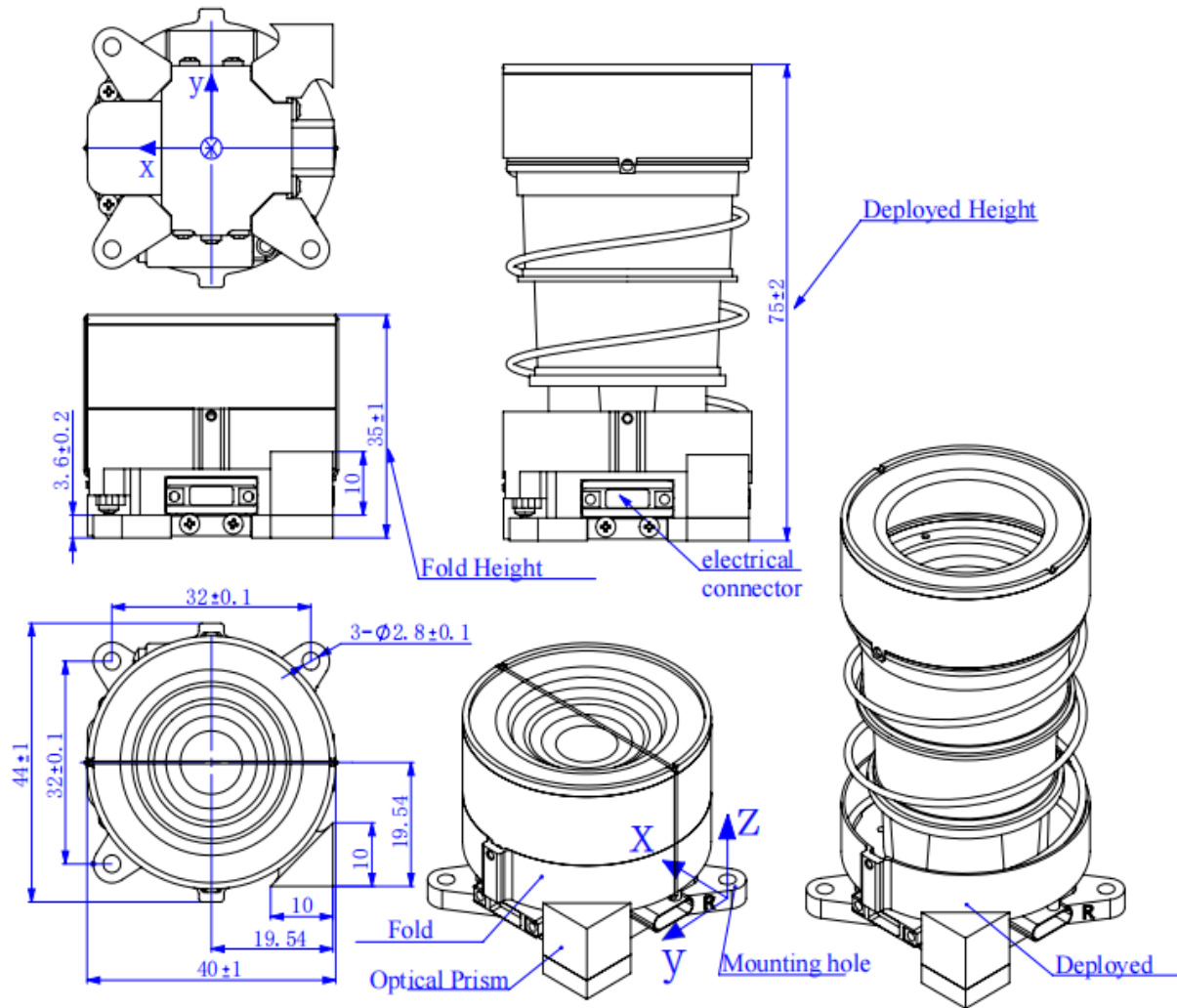

Note: This sketch should include body size, mounting size, mounting plane, mounting point (aperture and its tolerances, center distance and its tolerances), position tolerances for guide pins and holes, direction, location, type and number of electrical connectors, the operating hole, the lap (position and length), the registration measurement reference for calibration and testing.

Edited (Date) :			
Signed (Date) :	Mark	Changed number	Signature, date

### IDS 4: Thermal characteristics

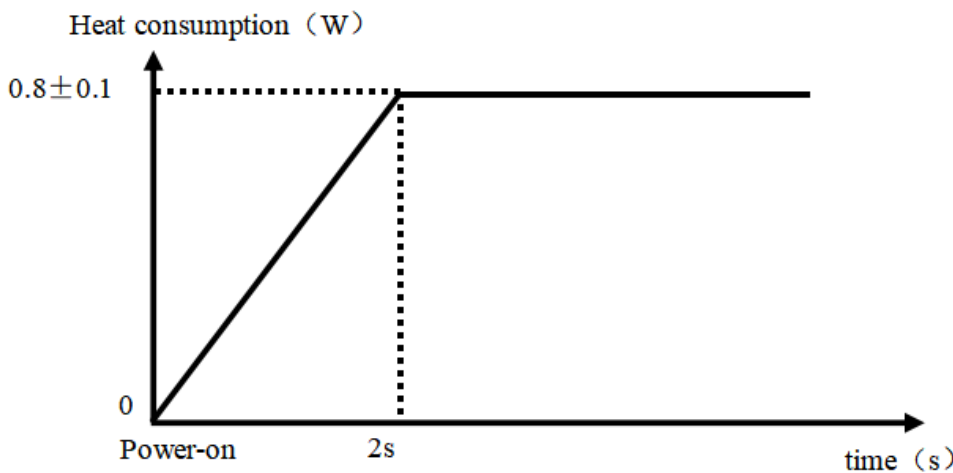
		File number	TYS-PST3SK4-IDS			
		Sub-system name				
		Device name	PST3SK4 Star Tracker		Stage mark	
		Device code				FM
Surface (except for mounting surface)	Aluminum alloy (2A12-T4)	Note: The inner surface of the baffle is treated with ultra black coating, $\epsilon_H: \geq 0.85$ , $\alpha_S: \geq 0.96$				
	Outside surface treatment: Yellow anodized					
	$\epsilon_H: \geq 0.6$					
Start temperature $^{\circ}\text{C}$ : -30~+40		The best operating temperature range $^{\circ}\text{C}$ : 20±5		Heat capacity J/K: 55		
Operating temperature range $^{\circ}\text{C}$ : -30~+40			Operating relative humidity range: $\leq 60\%$			
Storage temperature range $^{\circ}\text{C}$ : -30~+40			Storage relative humidity range: $\leq 70\%$			
Operating state heat consumption W: $0.8 \pm 0.1$ (per device)			Preparing state heat consumption W: 0 (per device)			
Description:						
						
Edited (Date) :						
Signed (Date) :		Mark	Changed number	Signature, date		

## IDS 5: Thermal Diagram

	File number	TYS-PST3SK4-IDS		
	Sub-system name			
	Device name	PST3SK4 Star Tracker	Stage mark	
	Device code			FM

Diagram:

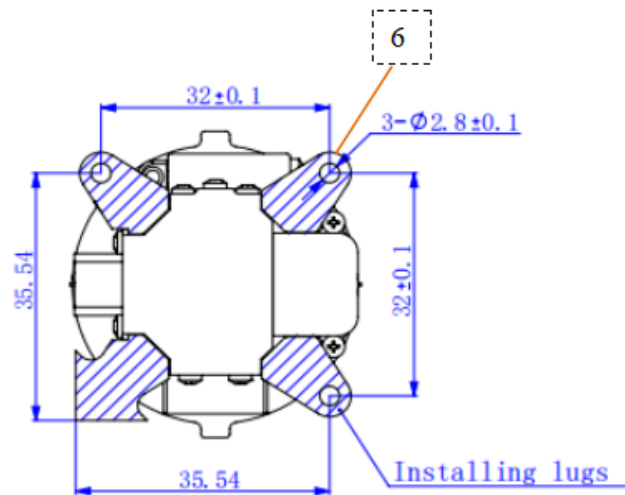
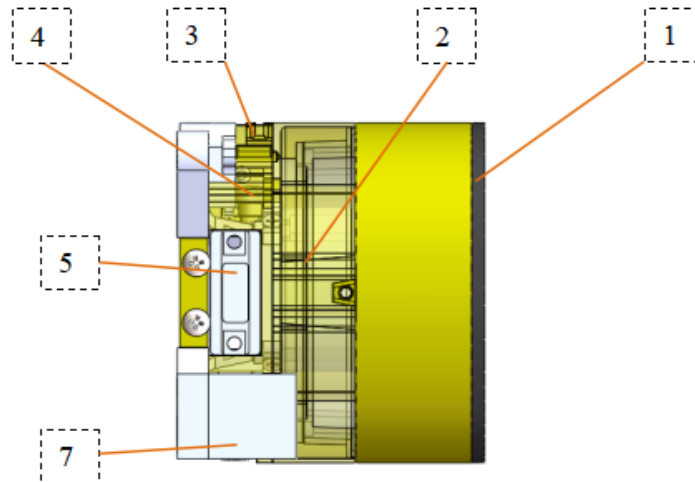

- 1—Baffle
- 2—Lens
- 3—Circuit box
- 4—Circuit board
- 5—Connector
- 6—Installing lugs (Contact surfaces)
- 7—optical prism

Edited (Date) :			
Signed (Date) :	Mark	Changed number	Signature, date

## IDS 6: Power

		File number		TYS-PST3SK4-IDS			
		Sub-system name					
		Device name		PST3SK4 Star Tracker		Stage mark	
		Device code				FM	
Working mode (long term/short term/others)		Long term	Single non-long-term power-up working hours S			Device number	1
Voltage V	Voltage stability %	Ripple voltage mV (P-P)	Device starting current characteristics (peak/duration)			Power W	
5	5%	100	2A/5ms			0.8±0.1	
<p>Note:</p> <p>1.Star tracker internal grounding designed isolation from the external structure.The external structure is ground by connecting.</p> <p>2.Electric current @the baffle depolyed(peak/duration):1.5A/30s</p>							
Edited (Date) :							
Signed (Date) :				Mark	Changed number	Signature, date	

## IDS 7: Electrical Connector Contact Assignment-Single PPS

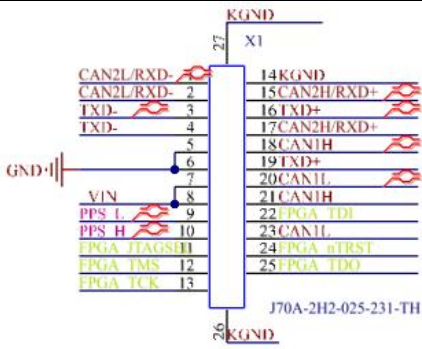
		File number		TYS-PST3SK4-IDS			
		Sub-system name					
		Device name		PST3SK4 Star Tracker		Stage mark	
		Device code				FM	
Name (by function)		Electrical connector P/N		J70A-2H2-025-231-TH		Needle / Hole	Hole
Contact number	Signal (function) description	Voltage/V	Current/A	Polar	Remarks (shielded / twisted)		
16,19	TXD+	RS422	RS422	422 Transmit+	3.16twisted, 4.19twisted		
3,4	TXD-	Standard	Standard	422 Transmit-			
15.17	CAN2H/RXD+	CAN2.0B/RS422	CAN2.0B/RS422	422 Receive+	1,15twisted, 2,17twisted		
1.2	CAN2L/RXD-	Standard	Standard	422 Receive-			
20.23	CAN1L	CAN2.0B	CAN2.0BStandard	CAN1L	18,20twisted, 21,23twisted		
18.21	CAN1H	Standard		CAN1H			
7.8	VIN	5V		Power	two-point two-wire		
5.6	GND	0V		Power Ground	two-point two-wire		
14	KGND				Structure ground		
10	PPS_H	RS422	RS422	PPS receive+	9,10twisted		
22	FPGA_TDI	Standard	Standard	PPS receive-			
12	FPGA_TMS		JTAG TDI		Internal use, prohibit external use		
13	FPGA_TCK		JTAG TMS				
24	FPGA_nTRST		JTAG TCK				
25	FPGA_TDO		JTAG nTRST				
11	FPGA_JTAGSEL		JTAG TDO				
							
Edited (Date):							
Signed (Date):		Mark		Changed number		Signature, date	

## IDS 8: Electrical Connector Contact Assignment-Different PPS

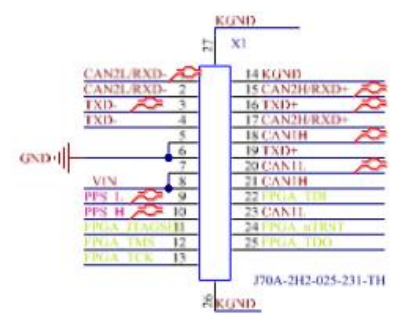
		File number		TYS-PST3SK4-IDS			
		Sub-system name					
		Device name		PST3SK4 Star Tracker		Stage mark	
		Device code				FM	
Name (by function)		Electrical connector P/N		J70A-2H2-025-231-TH		Needle / Hole	Hole
Contact number	Signal (function) description	Voltage/V	Current/A	Polar	Remarks (shielded / twisted)		
16,19	TXD+	RS422 Standard	RS422 Standard	422 Transmit+	3.16twisted, 4.19twisted		
3,4	TXD-			422 Transmit-			
15.17	CAN2H/RXD+	CAN2.0B/RS422 Standard	CAN2.0B/RS422 Standard	422 Receive+	1,15twisted, 2,17twisted		
1.2	CAN2L/RXD-			422 Receive-			
20.23	CAN1L	CAN2.0B Standard	CAN2.0BStandard	CAN1L	18,20twisted, 21,23twisted		
18.21	CAN1H			CAN1H			
7.8	VIN	5V	0.2A	Power	two-point two-wire		
5.6	GND	0V	0.2A	Power Ground	two-point two-wire		
14	KGND				Structure ground		
10	PPS_H	RS422 Standard	RS422 Standard	PPS receive+	9,10twisted		
9	PPS_L			PPS receive-			
22	FPGA_TDI		JTAG TDI		Internal use, prohibit external use		
12	FPGA_TMS		JTAG TMS				
13	FPGA_TCK		JTAG TCK				
24	FPGA_nTRST		JTAG nTRST				
25	FPGA_TDO		JTAG TDO				
11	FPGA_JTAGSEL		JTAG SEL				
							
Edited (Date):							
Signed (Date):		Mark	Changed number		Signature, date		

## IDS 9: Electrical Interface Features-Power

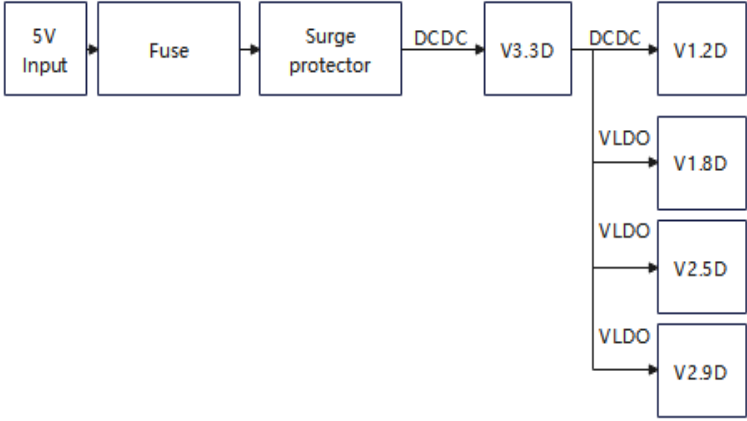
	File number	TYS-PST3SK4-IDS			
	Sub-system name				
	Device name	PST3SK4 Star Tracker		Stage mark	
	Device code				FM
Interface signal	Power supply				
Signal characteristics	5V power and the ground are two-point two-wire.				
Interface Circuit	 <pre> graph LR     A[5V Input] --&gt; B[Fuse]     B --&gt; C[Surge protector]     C -- DCDC --&gt; D[V3.3D]     D -- DCDC --&gt; E[V1.2D]     D -- VLDO --&gt; F[V1.8D]     D -- VLDO --&gt; G[V2.5D]     D -- VLDO --&gt; H[V2.9D]     </pre>				
Explanation					
Edited (Date):					
Signed (Date):		Mark	Changed number	Signature, date	

## IDS 10: Electrical Interface Features-RS422

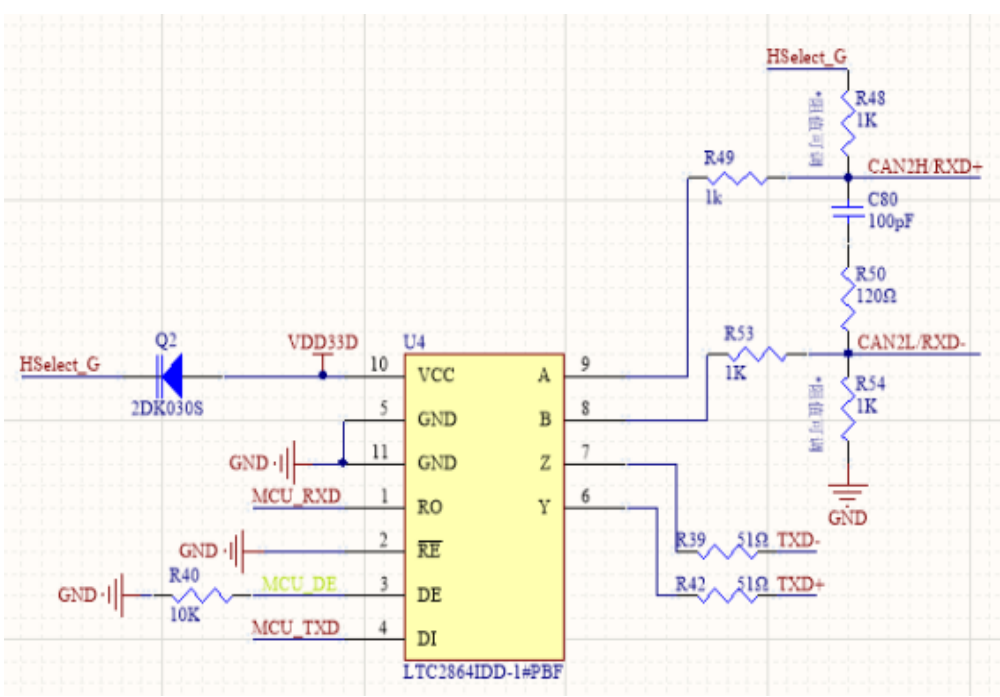
	File number	TYS-PST3SK4-IDS			
	Sub-system name				
	Device name	PST3SK4 Star Tracker	Stage mark		
	Device code			FM	
Interface signal	Digital signal, RS422.				
Signal characteristics	422 communication baud rate: 115200bps;The starting bit is one, the data bit is eight bits (the low bit precede the high bit), the stop bit is one, odd parity,one bit two-point two-wire				
Interface circuit					
Explanation					
Edited (Date):					
Signed (Date):	Mark	Changed number	Signature, date		

## IDS 11: Electrical Interface Features-Second pulse (different)

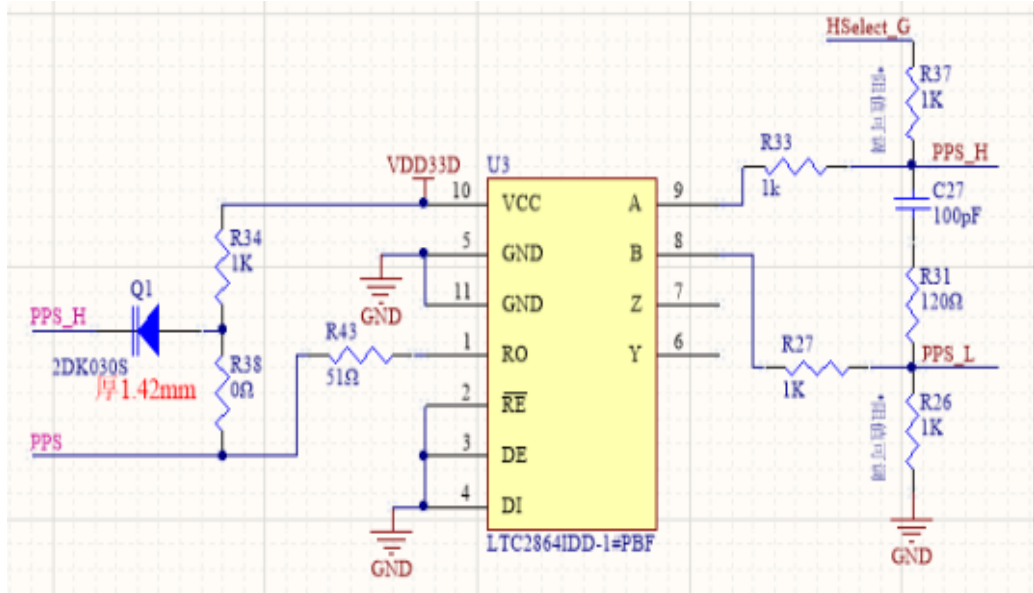
	File number	TYS-PST3SK4-IDS			
	Sub-system name				
	Device name	PST3SK4 Star Tracker	Stage mark		
	Device code			FM	
Interface signal	Second pulse				
Signal characteristics	@ Differential second pulse, the second integer is aligned by the lower edge, and the negative pulse width is 1ms.				
Interface circuit	Seconds pulse circuit				
					
Explanation					
Edited (Date):					
Signed (Date):	Mark	Changed number	Signature, date		

## IDS 12: Circuit and Interface Schematics

	File number	TYS-PST3SK4-IDS		
	Sub-system name			
	Device name	PST3SK4 Star Tracker	Stage mark	
	Device code			FM

Simplified diagram:

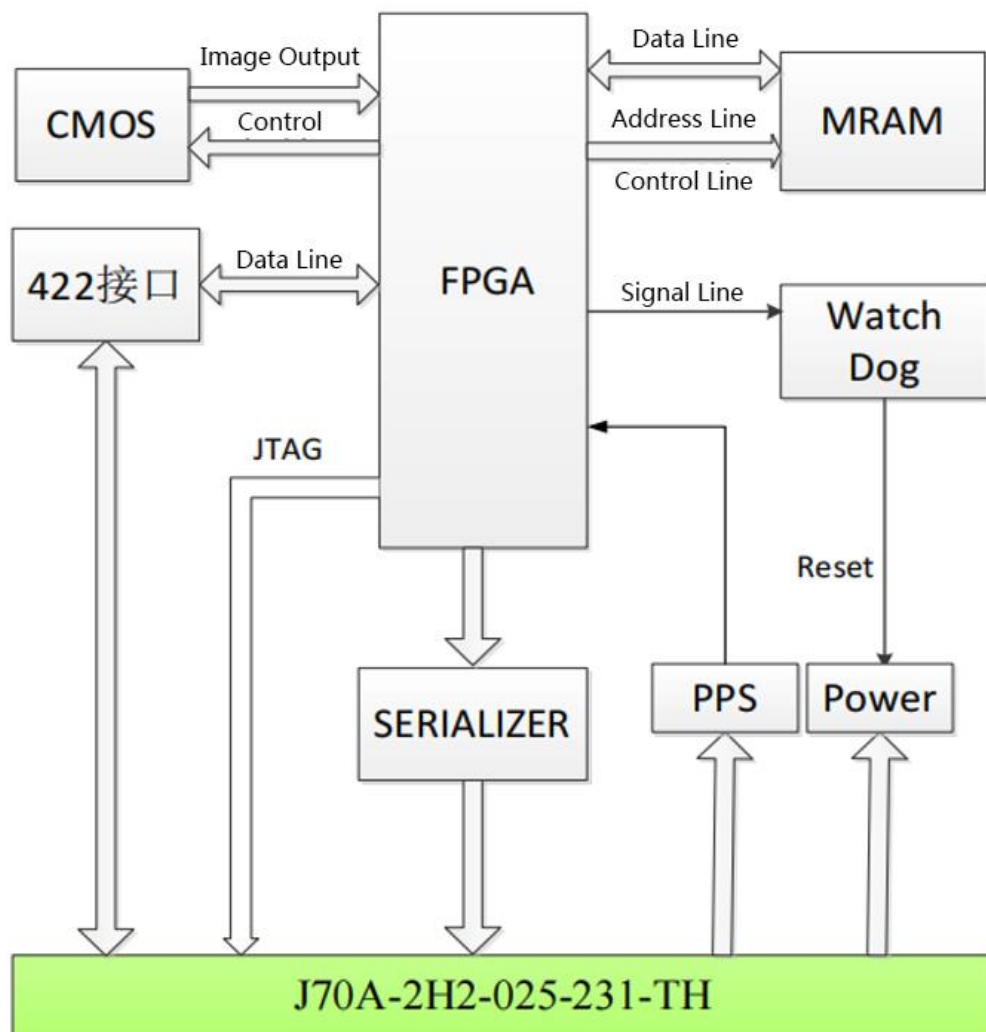

Edited (Date):			
Signed (Date):	Mark	Changed number	Signature, date

### IDS 13: Installation requirements

	File number	TYS-PST3SK4-IDS			
	Sub-system name				
	Device name	PST3SK4 Star Tracker	Stage mark		
	Device code			FM	

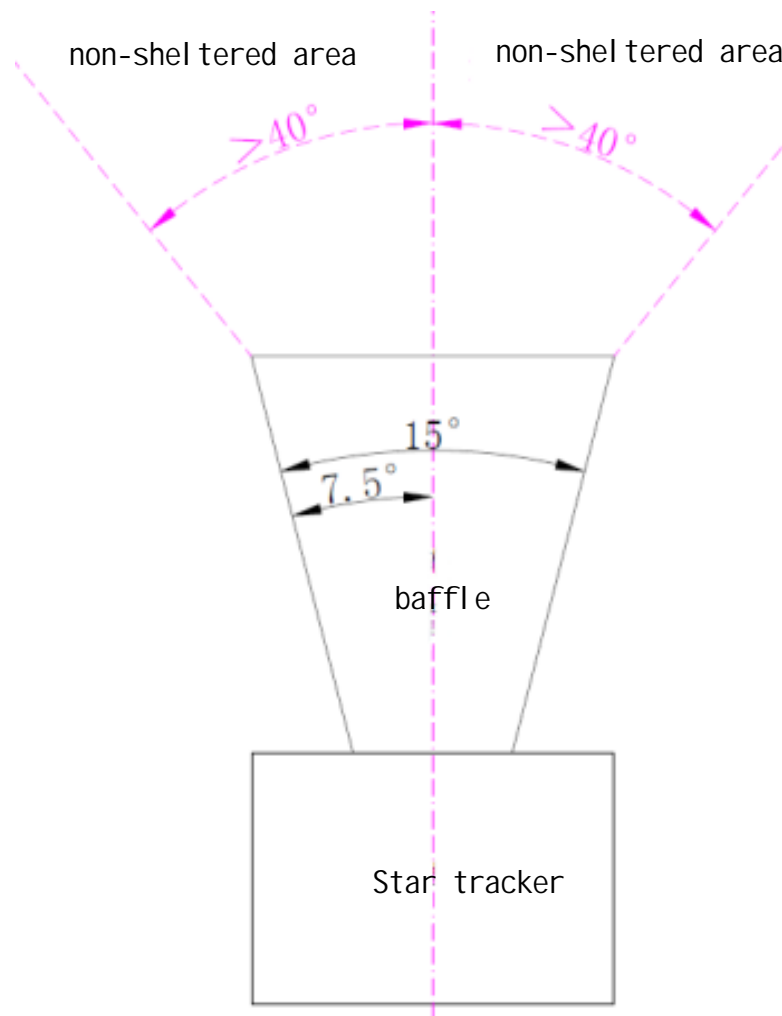

Be sure: Nothing sheltered in the field of view: the circular cone of 80° around the top of the Baffle.

Edited (Date):			
Signed (Date):	Mark	Changed number	Signature, date

## IDS 14: Device Description

	File number	TYS-PST3SK4-IDS		
	Sub-system name			
	Device name	PST3SK4 Star Tracker	Stage mark	
	Device code			FM
<p>Note: the special requirements for the interface and other inconvenient presentation are described in this section.</p>				
Edited (Date):				
Signed (Date):	Mark	Changed number	Signature, date	