

File number	Piece number



Label TYS-NST4SA2--IDS

Stage mark FM

Page 15

NST4S-A2 Star Tracker IDS

Signature

Edit : Fu Shuxin
Proofreading : Xiao Mingguo
Check : Wang Hongqiang
Standard check: Chai Yin
Approval : Wang Haijun

IDS1: DATA SHEET

	File number	TYS-NST4SA2-IDS			
	Sub-system name				
	Device name	NST4S-A2 Star Tracker		Stage mark	
	Device code				FM
Attitude Accuracy	Pointing: 3" (3 σ) Rolling: 30" (3 σ)				
Dynamic Range	@ 0.1°/s: 3" (Pointing, 3 σ); 30" (Rolling, 3 σ); @0.5°/s: 5" (Pointing, 3 σ); 50" (Rolling, 3 σ); @1.0°/s: 10" (Pointing, 3 σ); 100" (Rolling, 3 σ); @ 3°/s: follow up				
Data Validity	>98%@ 0.5°/s; >96%@0.5°/s ~1.5°/s; >90%@1.5°/s ~2°/s.				
Update Rate	$\geq 10\text{Hz}$				
Acquisition Rate	Max. $\leq 2\text{s}$				
Start-up Time	Better than 5s				
Exclusive Angle	Sun $\leq 25^\circ$; Earth or other stray light $\leq 20^\circ$				
Timing Accuracy	0.1ms @ synchronization pulse (SYNC pulse)				
Communitation	422				
Quaternion Continuity	the scalar of the quaternion: non-negative				
Life Time	7years @1200Km Orbit.				
Reliability	≥ 0.98 @ the end of a 7years running				
Edited (Date) :					
Signed (Date) :		Mark	Changed number	Signature, date	

IDS2: Mechanical Characteristics

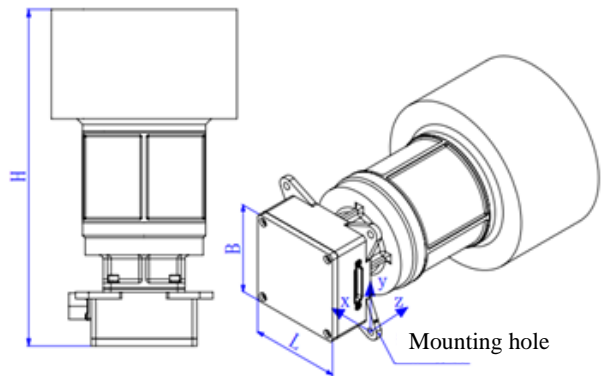
		File number		TYS-NST4SA2-IDS			
		Sub-system name					
		Device name		NST4S-A2 Star Tracker		Stage mark	
		Device code				FM	
Device weight ^{note)} 370±20 g			Device number:			√	
Weight characteristics	Envelope size mm	Envelope diameter: $\Phi 100 \pm 1$		Height: 182±2		√	
	Centroid position mm	X: 32±2	Y: 32±2	Z: 39±2		√	
	Inertia of centroid kg.mm ²	$P_X = 1351 \pm 3$	$P_Y = 1357 \pm 3$	$P_Z = 383 \pm 3$		Mea- sure- ment	Calc- ulatio- -n
Installation characteristics	Installed holes number: 4	Size of installed holes (tolerance) mm: $4 \times \Phi 4.3 \pm 0.1$		Material: 2A12-T4		Determination method (√)	
	Installation contacting area mm ² : 500			Note:			
	Installation surface flatness: 0.1mm/100mm×100mm						
	Installation surface roughness Ra μm : 3.2						
Installation surface state: the installation area is oxidized by conduction, and the remaining area is oxidized black.							
<p>Parameter relationship diagram (it should show the relative relationship between the coordinate frames, position of centroid, size of device body, location of installation surface, etc.):</p> <p>Note: the determination method refers to the way to determine the quality of device.</p>							
							
<p>Note: The origin of the coordinates lies in the geometric center of the outer surface of the lower shell (see "Instrument diagram");</p>							
Edited (Date) :							
Signed (Date) :		Mark		Changed number		Signature, date	

IDS3: Instrument Diagram

	File number	TYS-NST4SA2-IDS		
	Sub-system name			
	Device name	NST4S-A2 Star Tracker	Stage mark	
	Device code			FM

Note: This sketch should include body size, mounting size, mounting plane, mounting point (aperture and its tolerances, center distance and its tolerances), position tolerances for guide pins and holes, direction, location, type and number of electrical connectors, the operating hole, the lap (position and length), the registration measurement reference for calibration and testing.

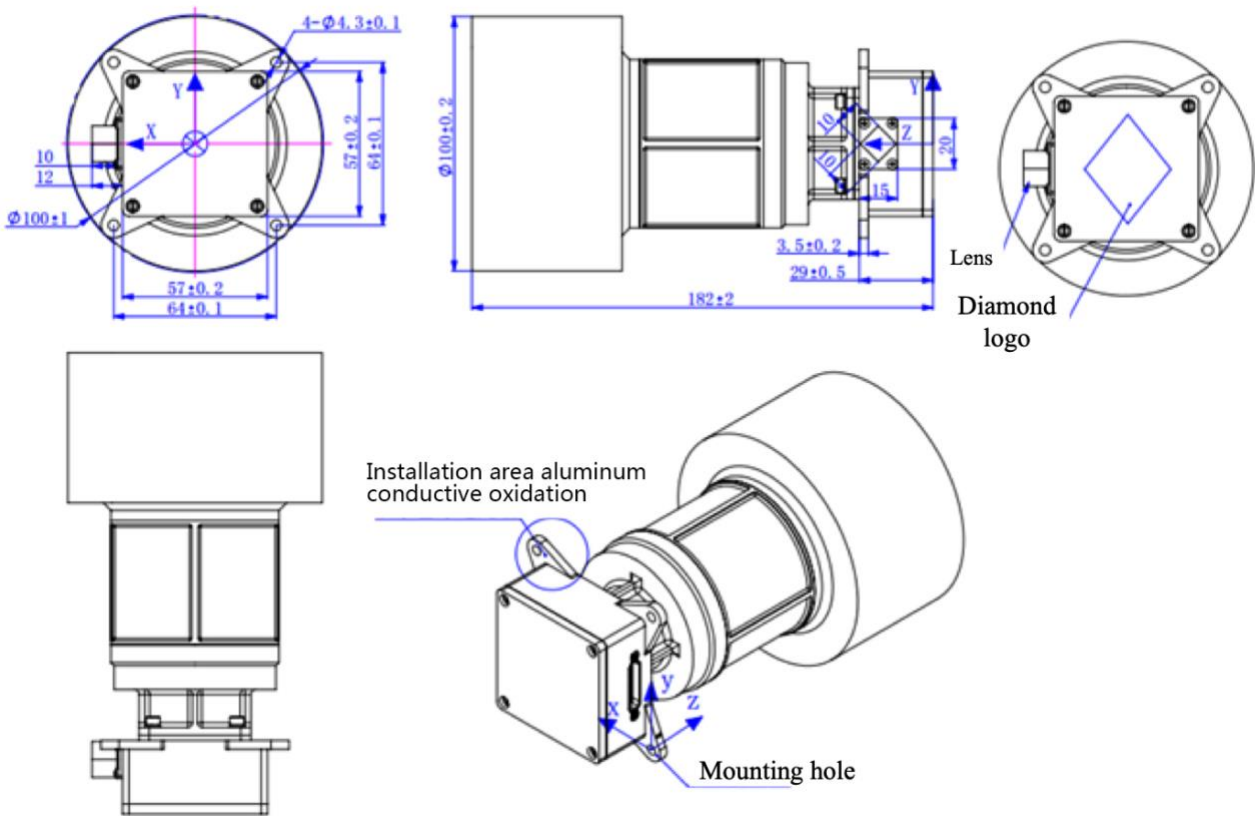

Edited (Date) :			
Signed (Date) :	Mark	Changed number	Signature, date

IDS4: Thermal characteristics

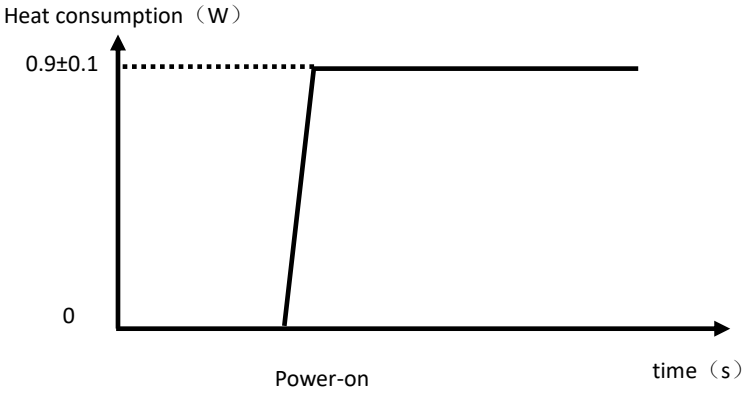
		File number	TYS-NST4SA2-IDS			
		Sub-system name				
		Device name	NST4S-A2 Star Tracker		Stage mark	
		Device code				FM
Surface (except for mounting surface)	Aluminum alloy (2A12-T4)	Note: The inner surface of the baffle is treated with ultrablack coating $\epsilon_H : \geq 0.85$, $S : \geq 0.96$				
	Outside surface treatment: aluminium color					
	$\epsilon_H : \geq 0.6$					
Start temperature $^{\circ}\text{C}$: -30~+40		Better Operating @ $^{\circ}\text{C}$: 20±5		Heat capacity J/K: 350		
Operating temperature range $^{\circ}\text{C}$: -30~+40		Operating relative humidity range: $\leq 60\%$				
Storage temperature range $^{\circ}\text{C}$: -30~+40		Storage relative humidity range: $\leq 70\%$				
Operating state heat consumption W: 0.9±0.1 (per device)						
						
Edited (Date) :						
Signed (Date) :		Mark	Changed number	Signature, date		

IDS 5: Thermal Diagram

	File number	TYS-NST4SA2-IDS		
	Sub-system name			
	Device name	NST4S-A2 Star Tracker	Stage mark	
	Device code			FM

Diagram:

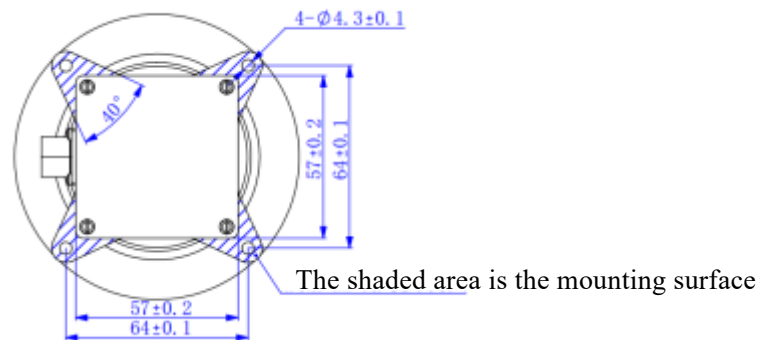
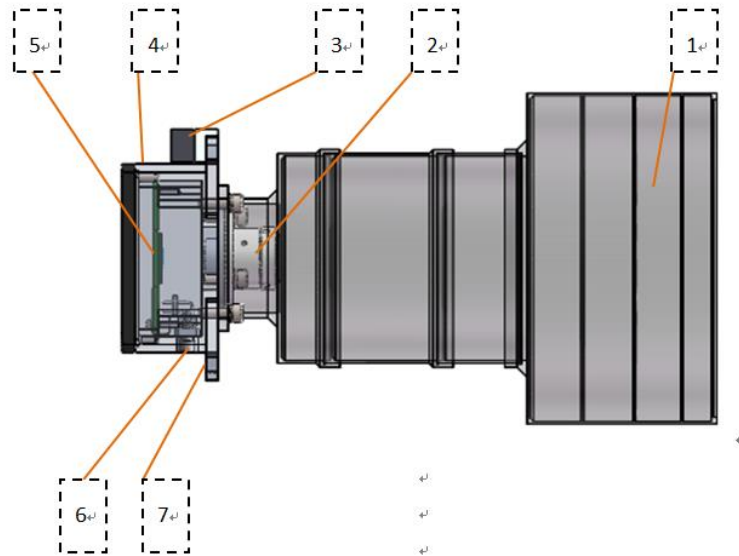

- 1—Baffle 2—Lens
- 3—Prism 4—Circuit box
- 5—Image sensor & Circuit board 6—Connector
- 7—Installing lugs (Contact surfaces)

Note: The hood and the star sensor circuit box are installed through 2mm polyimide heat insulation, and the lens shield is connected to the star sensor circuit box shell through screws to meet the lap requirements between metal components

Edited (Date) :			
Signed (Date) :	Mark	Changed number	Signature, date

IDS 6: Circuit and Interface Schematics

	File number	TYS-NST4SA2-IDS		
	Sub-system name			
	Device name	NST4S-A2 Star Tracker	Stage mark	
	Device code			FM

Simplified diagram:

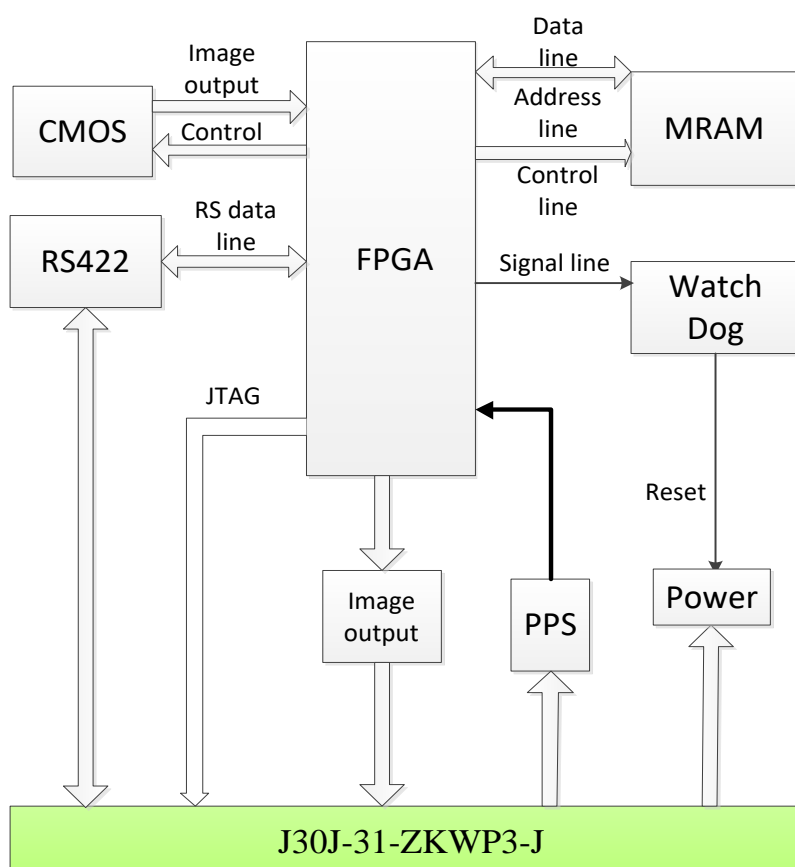

Edited (Date):			
Signed (Date):	Mark	Changed number	Signature, date

IDS 7: Power

		File number		TYS-NST4SA2-IDS			
		Sub-system name					
		Device name		NST4S-A2 Star Tracker		Stage mark	
		Device code					
Working mode (long term/short term/others)		Long term	Single non-long-term power-up working hours S			Device number	1
Voltage V	Voltage stability %	Ripple voltage mV (P-P)	Device starting current characteristics (peak/duration)			Power W	
5	\	100	2A/5ms			0.9±0.1	
<p>CAUTION: Safe Running Voltage Range: 4.8V ~ 5.4V</p>							
Edited (Date) :							
Signed (Date) :				Mark	Changed number	Signature, date	

IDS 8: Electrical Connector Contact Assignment

		File number		TYS-NST4SA2-IDS		Stage mark			
		Device name		NST4S-A2Star Tracker					
		Device code							
Name (by function)		XK-01		Electrical connector code		J30J-31ZKWP3-J		Needle / Hole	Hole
Contact number	Signal (function) description	Voltage/ V	Current/ A	Polar		Remarks (shielded / twisted)			
2, 18	TXD1-	RS422 standard	RS422 standard	Send asynchronously-		2,3 twisted, 18,19 twisted			
3, 19	TXD1+			Send asynchronously+					
4, 20	RXD1-	RS422 standard	RS422 standard	Asynchronous receiving-		4,5 twisted, 20,21 twisted			
5, 21	RXD1+			Asynchronous receiving+					
17	PPS H			Synchronization signals+		1,17 twisted			
15, 31	VIN	/	/	Power					
14, 30	GND	/	/	Power ground					
16	KGND	/	/	Structure ground		Structure ground			
22	FPGA_TDI	/	/	JTAG_TDI		Internal use, prohibit external use			
23	FPGA_TMS	/	/	JTAG_TMS					
24	FPGA_TCK	/	/	JTAG_TCK					
25	FPGA_JTAGSEL	/	/	JTAG_SEL					
26	FPGA_nTRST	/	/	JTAG_nTRST					
27	FPGA_TDO	/	/	JTAG_TDO					
6	Xclk_N	/	/	Cameralink Xclk-					
7	Xclk_P	/	/	Cameralink Xclk+					
8	X0_N	/	/	Cameralink X0-					
9	X0_P	/	/	Cameralink X0+					
10	X1_N	/	/	Cameralink X1-					
11	X1_P	/	/	Cameralink X1+					
12	X2_N	/	/	Cameralink X2-					
28	X2_P	/	/	Cameralink X2+					
13	X3_N	/	/	Cameralink X3-					
29	X3_P	/	/	Cameralink X3+					
Edited (Date):									
Signed (Date):		Mark		Changed number		Signature, date			

IDS 9: Electrical Interface Features-Power

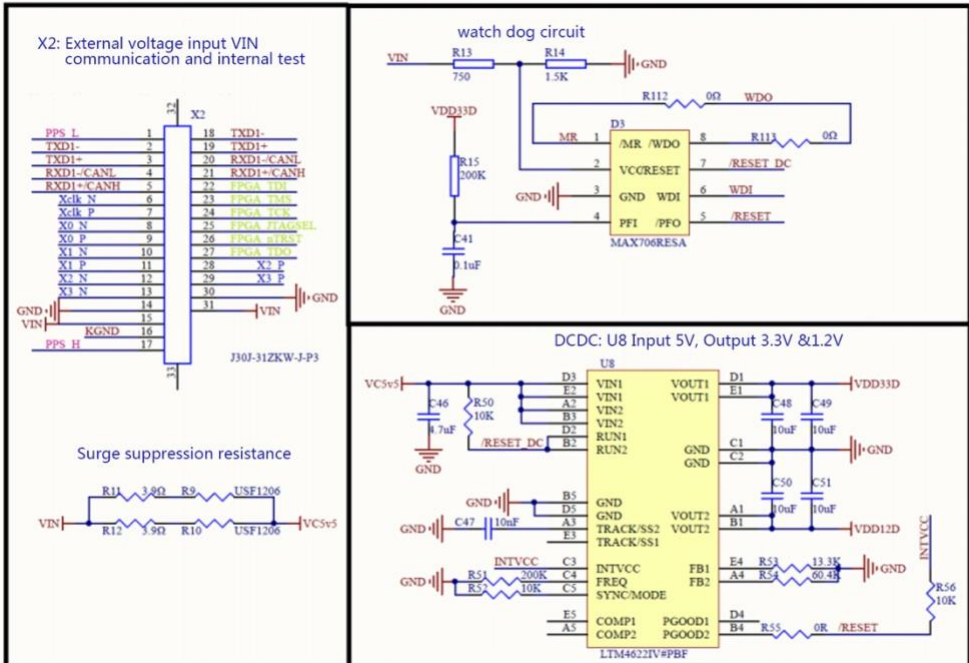
	File number	TYS-NST4SA2-IDS			
	Sub-system name				
	Device name	NST4S-A2 Star Tracker		Stage mark	
	Device code				
Interface signal	Power supply				
Signal characteristics	Operating voltage: 4.8V-5.4V; Reflected ripple : <100mV(p-p); Electric current @the baffle depolyed(peak/duration):2A/5s				
Interface Circuit					
Explanation	The power ground (GND) is isolated with the structure ground (KGND).				
Edited (Date):					
Signed (Date):	Mark	Changed number		Signature, date	

IDS 10: Electrical Interface Features-422

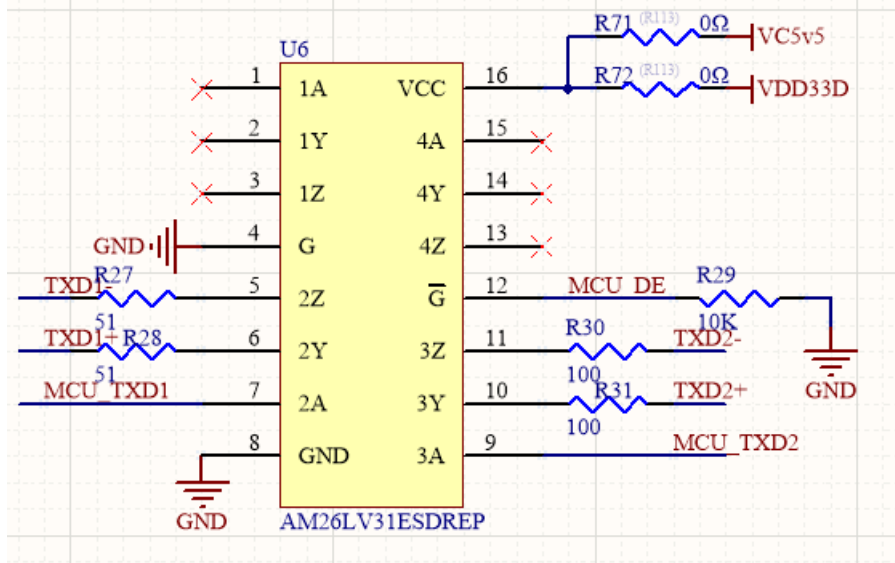
	File number	TYS-NST4SA2-IDS			
	Sub-system name				
	Device name	NST4S-A2 Star Tracker	Stage mark		
	Device code				FM
Interface signal	Digital signal, RS422. (Sent)				
Signal characteristics	422 communication baud rate: 115200bps; Meet the standard: EIA-422-B Interface Chip:AM26LV31ESDREP, ,3.3v				
Interface Circuit	 <p>The diagram shows the AM26LV31ESDREP chip (U6) with the following connections: - Pin 1 (1A): VCC, connected to VC5v5 via resistor R71 (0Ω). - Pin 2 (1Y): 4A, connected to VDD33D via resistor R72 (0Ω). - Pin 3 (1Z): 4Y, unconnected (marked with X). - Pin 4 (1Z): 4Y, unconnected (marked with X). - Pin 5 (2Z): G, connected to GND. - Pin 6 (2Y): 3Z, connected to TXD1+ via resistor R28 (51Ω). - Pin 7 (2A): 3Y, connected to MCU TXD1 via resistor R27 (51Ω). - Pin 8 (GND): 3A, connected to GND. - Pin 9: MCU TXD2, connected to TXD2+ via resistor R31 (100Ω). - Pin 10: TXD2-, connected to TXD2+ via resistor R30 (100Ω). - Pin 11: TXD2-, connected to TXD2+ via resistor R29 (10KΩ). - Pin 12: MCU DE, connected to TXD2+ via resistor R29 (10KΩ). - Pin 13: unconnected (marked with X). - Pin 14: unconnected (marked with X). - Pin 15: unconnected (marked with X). - Pin 16: unconnected (marked with X).</p>				
Explanation	TXD1+ & TXD1- are for connecting OBC. TXD2+ & TXD2- are internal used.				
Edited (Date):					
Signed (Date):		Mark	Changed number	Signature, date	

IDS 11: Electrical Interface Features-422

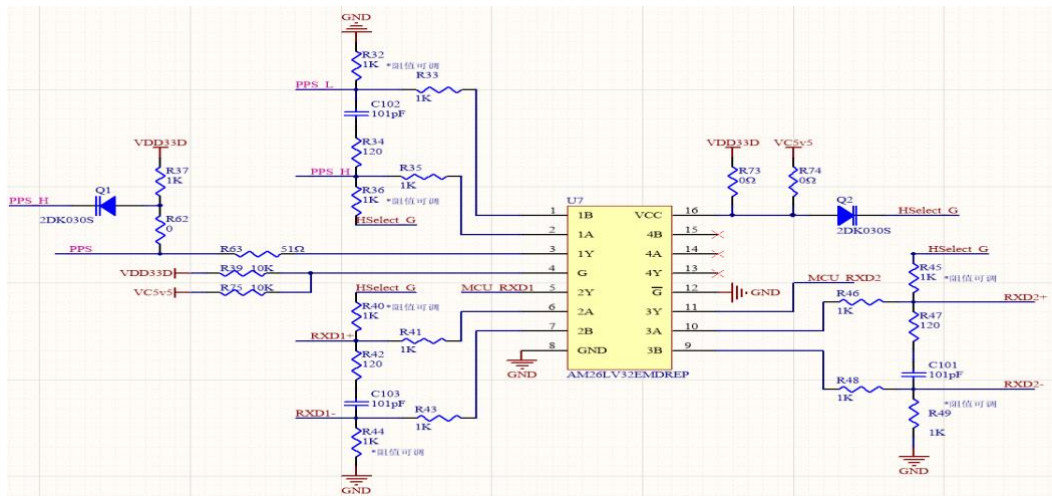
	File number	TYS-NST4SA2-IDS			
	Sub-system name				
	Device name	NST4S-A2 Star Tracker	Stage mark		
	Device code			FM	
Interface signal	Digital signal, RS422. (Received)				
Signal characteristics	422 communication baud rate: 115200bps; Meet the standard: EIA-422-B				
Interface Circuit					
Explanation	<p>Note: RXD1+, RXD1- are for connecting OBC. RXD2+, RXD2- are internal used.</p>				
Edited (Date):					
Signed (Date):		Mark	Changed number	Signature, date	

IDS 12: Electrical Interface Features-Second pulse(Single)

	File number	TYS-NST4SA2-IDS	
	Sub-system name		
	Device name	NST4S-A2 Star Tracker	Stage mark
	Device code		FM
Interface signal	Second pulse signal		
Signal characteristics	The second pulse signal input mode is differential and is triggered by the lower edge. the negative pulse width is 1~2ms. Meet the standard: EIA-422-B.		
Interface circuit	<p>Second pulse circuit</p>		
Explanation	R32、R33、R35、R34、R36、R63、R74、R75and C102 are not weld @ single second pulse.		
Edited (Date):			
Signed (Date):	Mark	Changed number	Signature, date

IDS 13: Electrical Interface Features-Second pulse(Different)

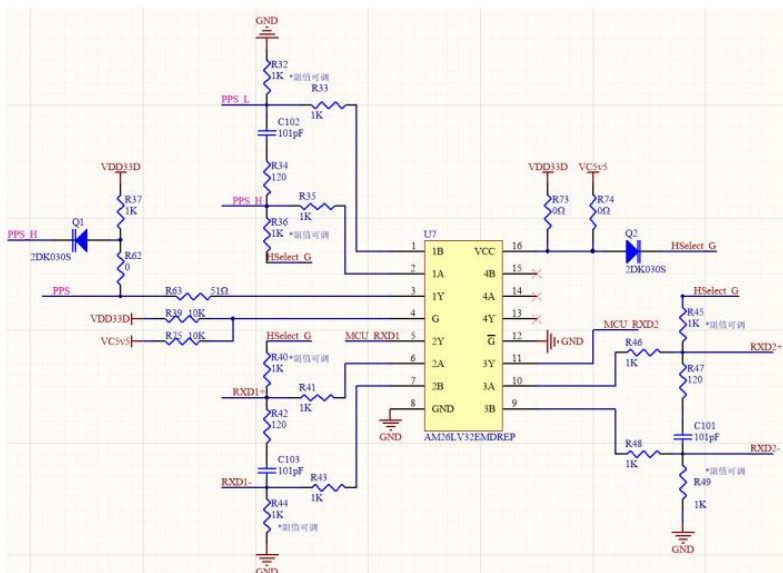
	File number	TYS-NST4SA2-IDS			
	Sub-system name				
	Device name	NST4S-A2 Star Tracker	Stage mark		
	Device code			FM	
Interface signal	Second pulse signal				
Signal characteristics	The second pulse signal input mode is differential and is triggered by the lower edge. the negative pulse width is 1~2ms. Meet the standard: EIA-422-B.				
Interface circuit	<p>Second pulse circuit</p> 				
Explanation	R37、R62、R74、R75 and Q1 are not weld@ different second pulse.				
Edited (Date):					
Signed (Date):		Mark	Changed number	Signature, date	

IDS 14: Installation requirements

	File number	TYS-NST4SA2-IDS		
	Sub-system name			
	Device name	NST4S-A2 Tracker	Star	Stage mark
	Device code			FM

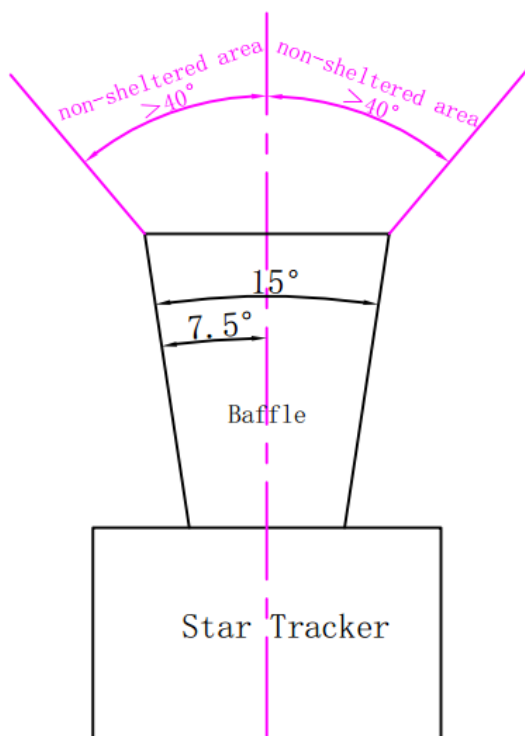

Installation Notes:

Be sure: Nothing sheltered in the field of view: the circular cone of 80° around the top of the Baffle.

Edited (Date):			
Signed (Date):	Mark	Changed number	Signature, date