

File number	Piece number



File Number TYS-NST20G3-IDS  
 Stage mark Z  
 Page 15

# NST20-G3 Star Tracker IDS

Signature

Edit : FUSHUXIN  
 Proofreading : WANG HONGQIANG  
 Check : XIAO MINGGUO  
 Standard check: CHAIYIN  
 Approval : WANGHAIJUN

## IDS 1: Performance Index

	File number	TYS-NST20G3-IDS			
	Sub-system name				
	Device name	NST20-G3 Star Tracker		Stage mark	
	Device code				FM
Attitude Accuracy	Pointing: 1" (3 $\sigma$ ) Rolling: 6" (3 $\sigma$ )				
Dynamic Range	@5°/s: 8" (Pointing, 3 $\sigma$ ); 100" (Rolling, 3 $\sigma$ );				
Update Rate	$\geq 10\text{Hz}$				
Acquisition Rate	Max. $\leq 2\text{s}$				
Start-up Time	Better than 5s				
Exclusive Angle	Sun: better than 25°; Earth: better than 20°				
Timing Accuracy	0.1ms @ synchronization pulse (SYNC pulse)				
Quaternion Continuity	the scalar of quaternion: non-negative				
Life Time	7years @500Km Orbit 5years @1000Km Orbit				
Communication	422				
Reliability	$\geq 0.98$ @ the end of 5/7years running				
Edited (Date) :					
Signed (Date) :		Mark	Changed number	Signature, date	

## IDS 2: Mechanical Characteristics

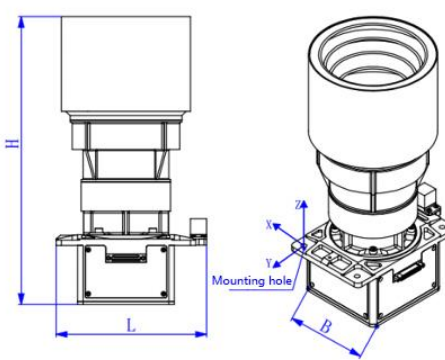
		File number	TYS-NST20G3-IDS				
		Sub-system name					
		Device name	NST20-G3 Star Tracker			Stage mark	
		Device code					FM
Device weight <sup>(note)</sup> $1.2 \pm 0.2\text{kg}$		Device number: 1				√	
Weight characteristics	Envelope size mm	L: $140 \pm 0.5$	B: $120 \pm 0.2$	H: $268 \pm 2$		√	
	Centroid position mm	X: $-34 \pm 2$	Y: $-58 \pm 2$	Z: $25 \pm 2$		√	
	Inertia of centroid $\text{kg}\cdot\text{mm}^2$	$7223 \pm 5$	$7410 \pm 5$	$2243 \pm 5$	Measurement	Calculation	Estimate
Installation characteristics	Installed holes number: 4	Size of installed holes (tolerance) mm: $4-\Phi 5.5 \pm 0.1$		Material: 2A12-T4	Determination method (√)		
	Installation contacting area $\text{mm}^2$ : 3600	Note:					
	Installation surface flatness: 0.1mm						
	Installation surface roughness $R_a$ $\mu\text{m}$ : $3.2\mu\text{m}$						
	Installation surface flatness: 0.1mm/100mm×100mm						
Installation surface state: the installation area is oxidized by conduction, and the remaining area is oxidized black.							
<p>Parameter relationship diagram (the relative relationship between the coordinate frames, position of centroid, size of device body, location of installation surface, etc.):</p> <p>Note: the determination method refers to the way to determine the weight of device.</p>							
							
<p>Note: The origin of the coordinates lies in the geometric center of the outer surface of the lower shell (see "Instrument diagram");</p>							
Edited (Date) :							
Signed (Date) :		Mark	Changed number		Signature, date		

### IDS 3: Instrument Diagram

	File number	TYS-NST20G3-IDS		
	Sub-system name			
	Device name	NST20-G3 Star Tracker	Stage mark	
	Device code			FM

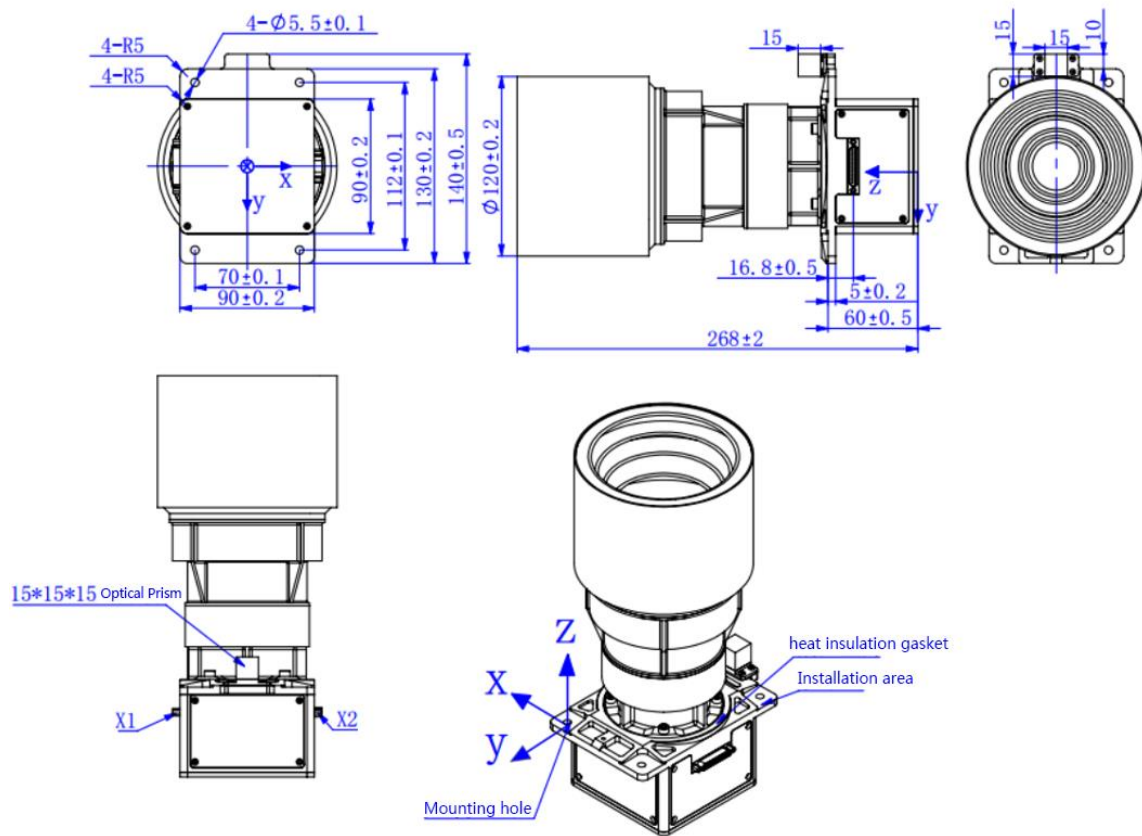

**Note:**

This sketch should include body size, mounting size, mounting plane, mounting point (aperture and its tolerances, center distance and its tolerances), position tolerances for guide pins and holes, direction, location, type and number of electrical connectors, the operating hole, the lap (position and length), the registration measurement reference for calibration and testing.

Edited (Date) :			
Signed (Date) :	Mark	Changed number	Signature, date

### IDS 4: Thermal characteristics

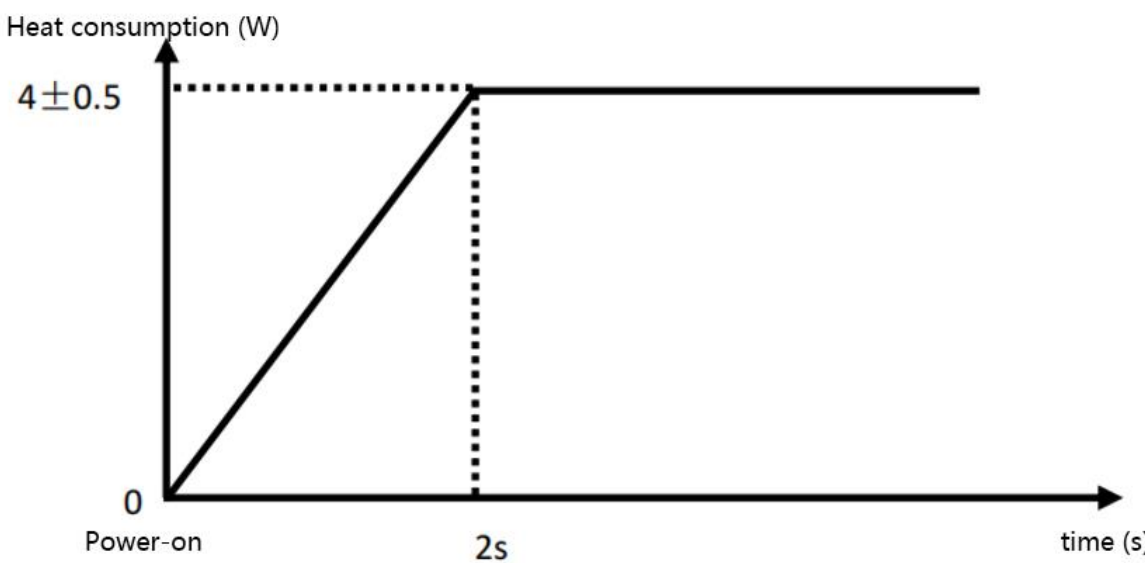
		File number	TYS-NST20G3-IDS		
		Sub-system name			
		Device name	NST20-G3 Star Tracker		Stage mark
		Device code			FM
Surface (except for mounting surface)	Aluminum alloy (2A12-T4)	Note: The inner surface of the baffle is treated with ultra black coating, $\epsilon_H: \geq 0.85, \alpha_S: \geq 0.96$			
	Outside surface treatment: Black anodized				
	$\epsilon_H: \geq 0.85$				
	Preparing state heat consumption W: 0 (per device)				
Start temperature $^{\circ}\text{C}$ : -30~+45		Heat capacity J/K: 1200			
Operating temperature range $^{\circ}\text{C}$ : -40~+45		The best operating temperature range $^{\circ}\text{C}$ : 0~+10			
Storage temperature range $^{\circ}\text{C}$ : -40~+45		Operating relative humidity range: $\leq 60\%$			
Operating state heat consumption W: $4 \pm 0.5$ (per device)		Storage relative humidity range: $\leq 70\%$			
<p>Description:</p> 					
Edited (Date) :					
Signed (Date) :		Mark	Changed number	Signature, date	

## IDS 5: Thermal Diagram

	File number	TYS-NST20G3-IDS		
	Sub-system name			
	Device name	NST20-G3 Star Tracker	Stage mark	
	Device code			FM

Diagram:

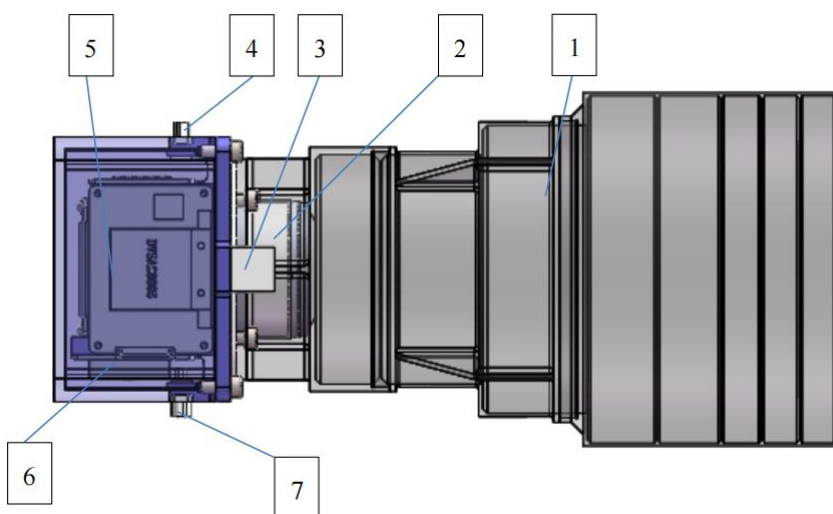

- 1—Baffle    2—Lens
- 3—Prism    4—X1 Connector
- 5—Circuit board    6—Circuit box
- 7—X2 Connector

The power of the circuit board:  $4 \pm 0.5W$

Edited (Date) :			
Signed (Date) :	Mark	Changed number	Signature, date

## IDS6 : Circuit and Interface Schematics

	File number	TYS-NST20G3-IDS		
	Sub-system name			
	Device name	NST20-G3 Star Tracker	Stage mark	
	Device code			FM

Diagram: The structure of Pico Star Tracker

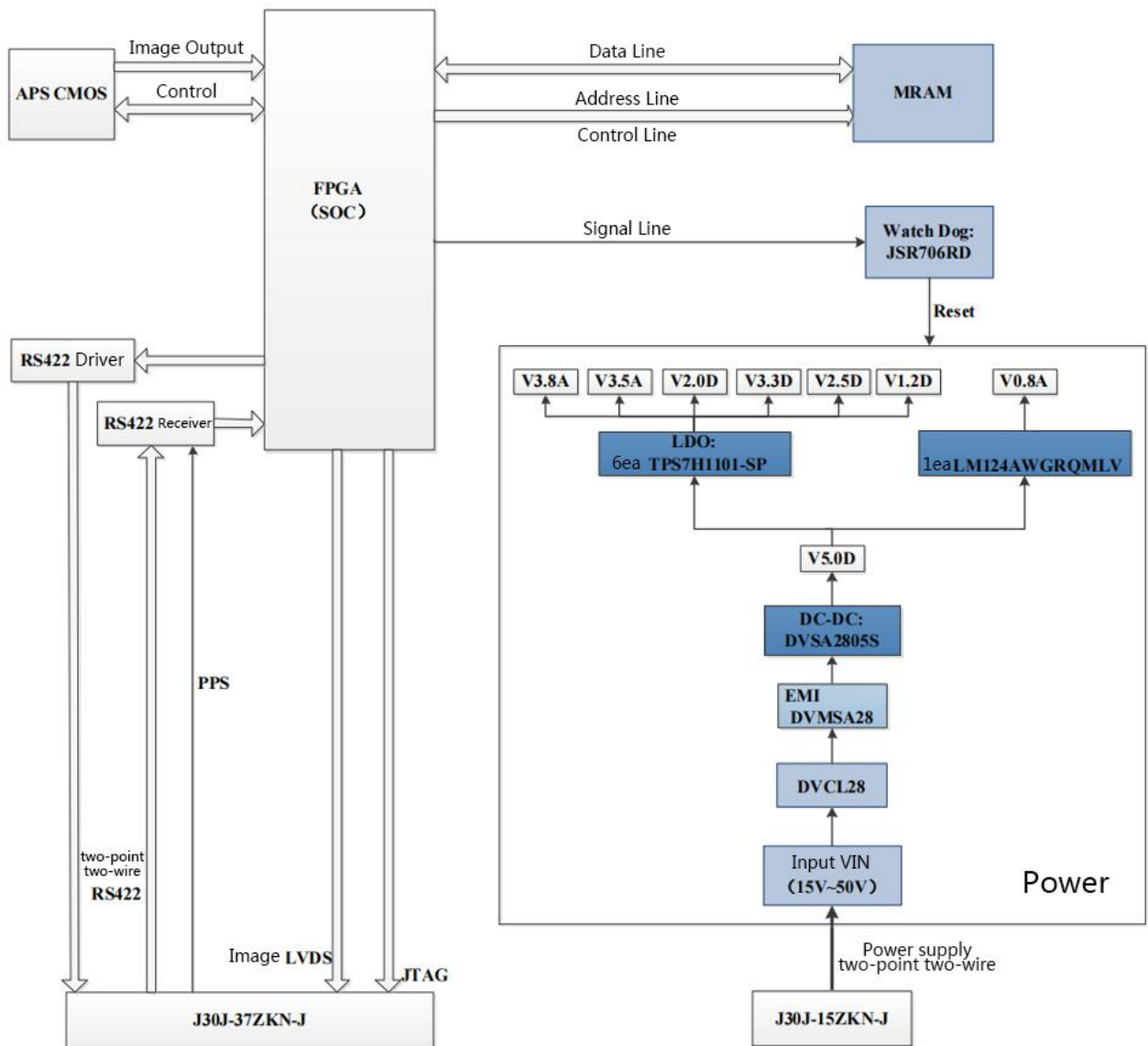

Edited (Date) :

Signed (Date) :

Mark

Changed number

Signature, date

## IDS 7: Power

		File number		TYS-NST20G3-IDS			
		Sub-system name					
		Device name		NST20-G3 Star Tracker		Stage mark	
		Device code				FM	
Working mode (long term/short term/others)		Long term		Single non-long-term power-up working hours S		Device number	
						1	
Voltage V	Voltage stability %	Ripple voltage mV (P-P)	Device starting current characteristics (peak/duration)			Power W	
28	21~29.5	500	2A/10ms			4±0.5	
Edited (Date) :							
Signed (Date) :				Mark		Signature, date	



### IDS 8: Electrical Connector

		File number		TYS-NST20G3-IDS			
		Sub-system name					
		Device name		NST20-G3 Star Tracker		Stage mark	
		Device code					FM
Name of the connector	Needle/Hole	Number of the Needle/Hole	Connector	Electrical Connector P/N	Note		
X1	Hole	37	Communication	J30J-37ZKN-J	X1		
X2	Hole	15	Power	J30J-15ZKN-J	X2		
Edited (Date) :							
Signed (Date) :			Mark	Changed number	Signature, date		

## IDS 9: Electrical Connector Contact Assignment (X1)

		File number		TYS-NST20G3-IDS							
		Sub-system name									
		Device name		NST20-G3 Star Tracker		Stage mark					
		Device code					FM				
Name (by function)		X1		Electrical connector P/N		J30J-37ZKN-J		Needle / Hole	Hole		
Contact number	Signal (function) description	Voltage/V	Current/A	Polar		Remarks (shielded / twisted)					
9、27	GND	0	0	-							
10、28	TXD1+	RS-422 standard	RS-422 standard	422 Transmit+		10、11twisted 28、29twisted					
11、29	TXD1-			422 Transmit-							
12、30	TXD2+	RS-422 standard	RS-422 standard	422 Transmit+		12、13twisted 30、31twisted					
13、31	TXD2-			422 Transmit-							
14、32	RXD1+	RS-422 standard	RS-422 standard	422 Receive +		14、15twisted 32、33twisted					
15、33	RXD1-			422 Receive -							
16、34	RTS+	RS-422 standard	RS-422 standard	RTS Differential+		16、17twisted 34、35twisted					
17、35	RTS-			RTS Differential+							
18、36	PPS_H	RS-422 standard	RS-422 standard	Seconds pulse difference+		18、19twisted 36、37twisted					
19、37	PPS_L			Seconds pulse difference-							
1	X3_P	LVDS standard	LVDS standard	CameraLink X3+		Internal use, prohibit external use					
20	X3_N			CameraLink X3-							
2	X2_P	LVDS Standard	LVDS Standard	CameraLink X2+							
21	X2_N			CameraLink X2-							
3	X1_P	LVDS Standard	LVDS Standard	CameraLink X1+							
22	X1_N			CameraLink X1-							
4	X0_P	LVDS Standard	LVDS Standard	CameraLink X0+							
23	X0_N			CameraLink X0-							
5	Xclk_P	LVDS Standard	LVDS Standard	CameraLink Xclk+							
24	Xclk_N			CameraLink Xclk-							
6	FPGA_nTRST			JTAG_nTRST							
25	FPGA_TMS			JTAG_TMS							
7	FPGA_TDO			FPGA_TDO							
26	FPGA_TDI			FPGA_TDI							
8	FPGA_TCK			FPGA_TCK							

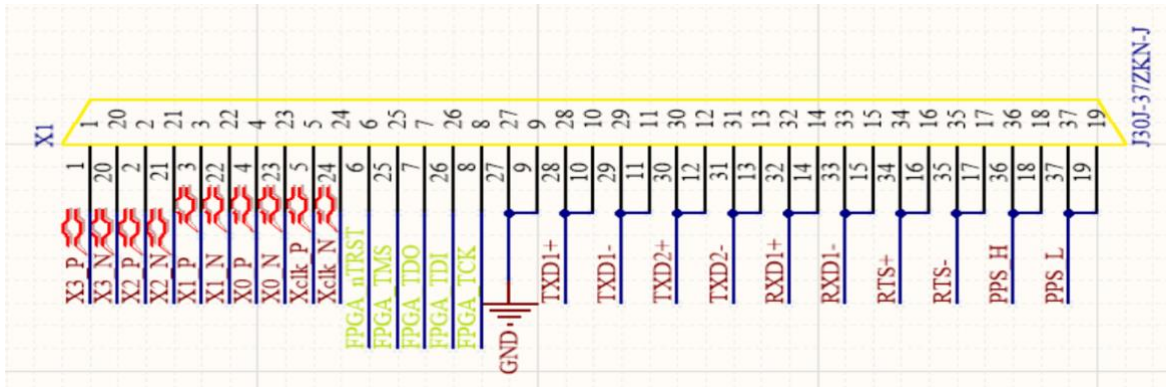

Edited (Date):

Signed (Date):

Mark

Changed number

Signature, date

## IDS 10: Electrical Connector Contact Assignment (X2)

	File number	TYS-NST20G3-IDS	
	Sub-system name		
	Device name	NST20-G3 Star Tracker	Stage mark
	Device code		F M

Name (by function)	X2	Electrical connector code	J30J-15ZKN-J	Needle / Hole	Hole
Contact number	Signal (function) description	Voltage/V	Current/A	Polar	Remarks (shielded / twisted)
1、9	VIN+ Power+	21~29.5V	0.18A	+	1、2twisted 9、10twisted
2、10	VIN+ Power-	0	0	-	
5、13	KGND	0	0	-	
7、8、15	Structure Ground	0	0	-	
3、4、6、11、12、14	None				Internal use

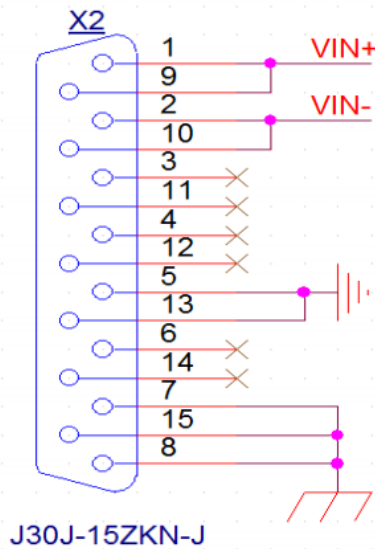

Edited (Date):			
Signed (Date):	Mark	Changed number	Signature, date

## IDS 11: Electrical Interface Features-Power

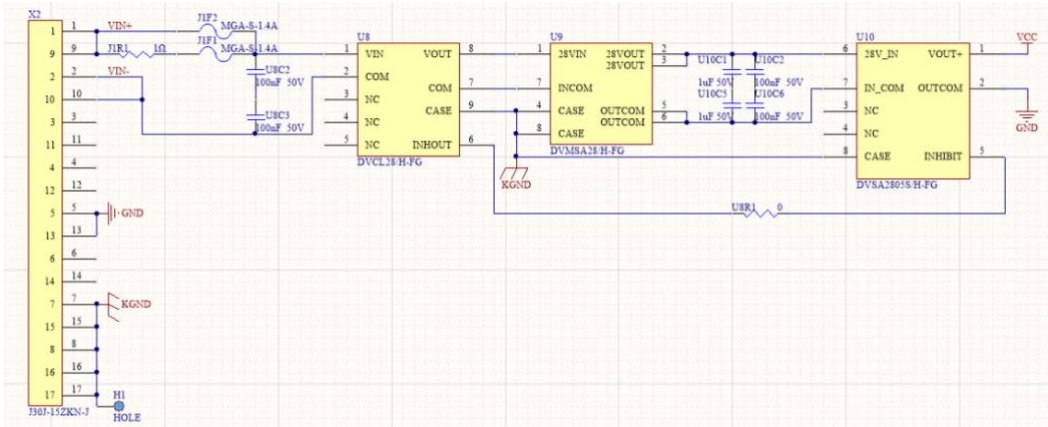
	File number	TYS-NST20G3-IDS			
	Sub-system name				
	Device name	NST20-G3 Star Tracker	Stage mark		
	Device code			FM	
Interface signal	Power supply				
Signal characteristics	28V power and the ground are two-point two-wire.				
Interface Circuit					
Explanation					
Edited (Date):					
Signed (Date):		Mark	Changed number	Signature, date	

## IDS 12: Electrical Interface Features-RS422

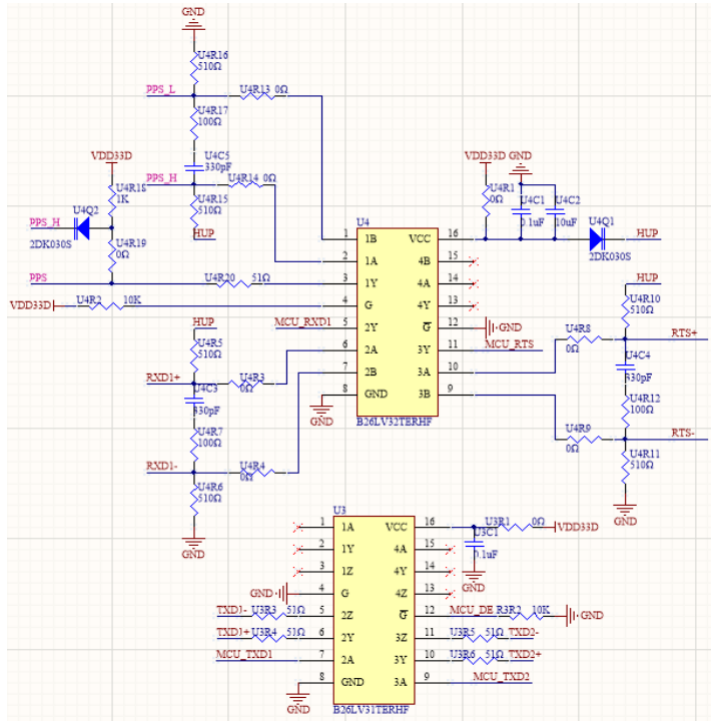
	File number	TYS-NST20G3-IDS			
	Sub-system name				
	Device name	NST20-G3 Star Tracker	Stage mark		
	Device code			FM	
Interface signal	Digital signal, RS422				
Signal characteristics	422 communication baud rate: 115200bps; two-point two-wire				
Interface circuit					
Explanation					
Edited (Date):					
Signed (Date):		Mark	Changed number	Signature, date	

## IDS 13: Electrical Interface Features-Second pulse (Different)

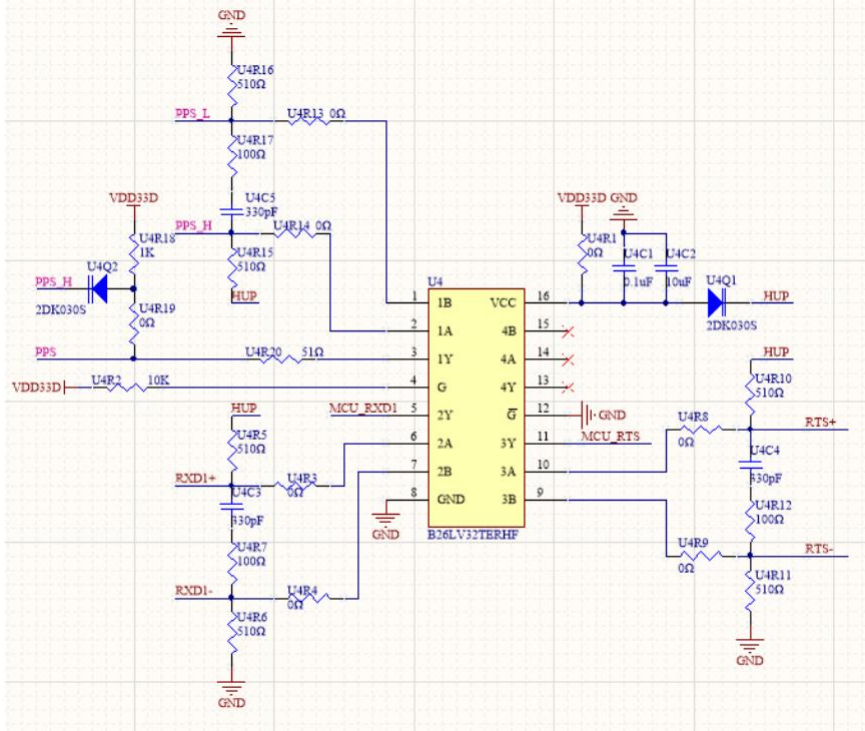
	File number	TYS-NST20G3-IDS			
	Sub-system name				
	Device name	NST20-G3 Star Tracker	Stage mark		
	Device code			FM	
Interface signal	Second pulse signal				
Signal characteristics	@ Differential second pulse, the second integer is aligned by the lower edge, and the negative pulse width is 1ms.				
Interface circuit					
Explanation	U4R18、U4R19、U4Q2 are not weld @different PPS				
Edited (Date):					
Signed (Date):		Mark	Changed number	Signature, date	

## IDS 14: Installation requirements

	File number	TYS-NST20G3-IDS	
	Sub-system name		
	Device name	NST20-G3 Star Tracker	Stage mark
	Device code		F M

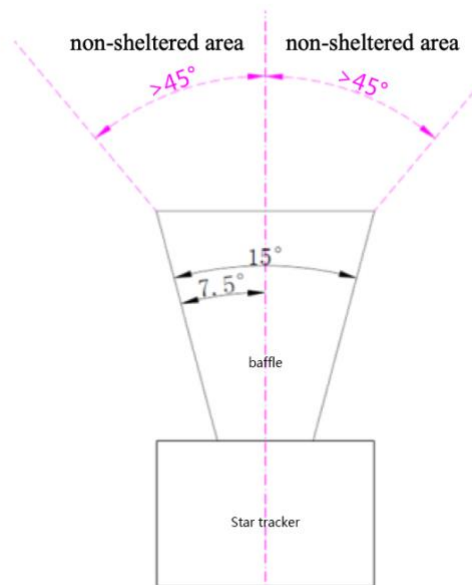

Be sure: Nothing sheltered in the field of view: the circular cone of 90° around the top of the Baffle.

Edited (Date):			
Signed (Date):	Mark	Changed number	Signature, date